



**GLOBAL ATLANTIC ASSURANCE LIMITED**  
**(A WHOLLY-OWNED SUBSIDIARY OF GLOBAL ATLANTIC FINANCIAL LIMITED)**

**FINANCIAL CONDITION REPORT**  
**FOR THE YEAR ENDED DECEMBER 31, 2022**

**DECLARATION OF FINANCIAL CONDITION REPORT**

(Prepared in accordance with Section 6A of the Insurance Act 1978)

For the year ended December 31, 2022

We, the undersigned senior executives of Global Atlantic Assurance Limited ("the Insurer"), declare that to the best of our knowledge and belief, the Financial Condition Report fairly represents the financial condition of the Insurer in all material respects.

Senior Executives:

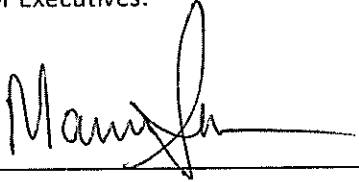

Chief Executive Officer – Manu Sareen

Date: April 24, 2023

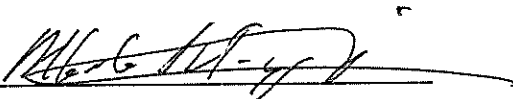

Chief Financial Officer – Alberto Autmezguine

Date: April 24, 2023

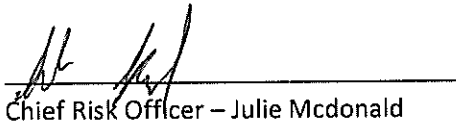

Chief Risk Officer – Julie McDonald

Date: April 24, 2023

## **Executive Summary**

This Financial Condition Report (“FCR”) is prepared in accordance with the Insurance (Public Disclosure) Rules 2015. This FCR documents the measures governing the business operations, corporate governance framework, solvency, and financial results of Global Atlantic Assurance Limited, or “GAAL” or “the Company” for the year ended December 31, 2022. This FCR is prepared to provide information to enable an informed assessment on how GAAL’s business is run in a prudent manner.

The Company was incorporated on January 29, 2018, as a Bermuda exempted company under the name Global Atlantic Re II Limited and registered under the Insurance Act of 1978, as amended as a dual licensed insurer: (i) a Class E insurer license to write Long-Term (life) reinsurance business and (ii) a Class 3A insurer to write General Business. Effective April 24, 2018, the Company changed its name to Global Atlantic Assurance Limited.

All financial information is presented in accordance with United States GAAP (U.S. GAAP) basis unless otherwise stated.

## Section I – Business and Performance

### a. Name of Insurer

Global Atlantic Assurance Limited

### b. Supervisors

#### *Insurance Supervisor*

Bermuda Monetary Authority (“BMA”)

BMA House

43 Victoria Street, Hamilton, HM 12

Bermuda

#### *Group Supervisor*

Indiana Department of Insurance

311 W. Washington Street, Suite 300

Indianapolis, IN 46204-2787

United States of America

### c. Approved Auditor

#### *Bermuda Statutory Reporting*

Deloitte Limited

Corner House

20 Parliament Street

Hamilton, HM 12

Bermuda

#### *U.S. GAAP Reporting*

Deloitte & Touche LLP

41st Floor

30 Rockefeller Plaza

New York, NY 10112

United States of America

### d. Ownership Details

GAAL is a direct and wholly-owned subsidiary of Global Atlantic Financial Limited, or “GAFL”. GAFL is a wholly-owned subsidiary of The Global Atlantic Financial Group LLC, or “TGAFG”, a Bermuda limited liability company. GAFL and TGAFG. Equity in TGAFG is approximately 63.3% owned by Magnolia Parent LLC (“Magnolia”), a KKR & Co. Inc., or “KKR” subsidiary and approximately 36.7% owned by several third-party investors.

### e. Group Structure

The following provides details of TGAFG’s Group structure as of December 31, 2022. Operating entities are shown, but the chart excludes certain other special purpose holding companies and subsidiaries within The Global Atlantic Financial Group LLC.

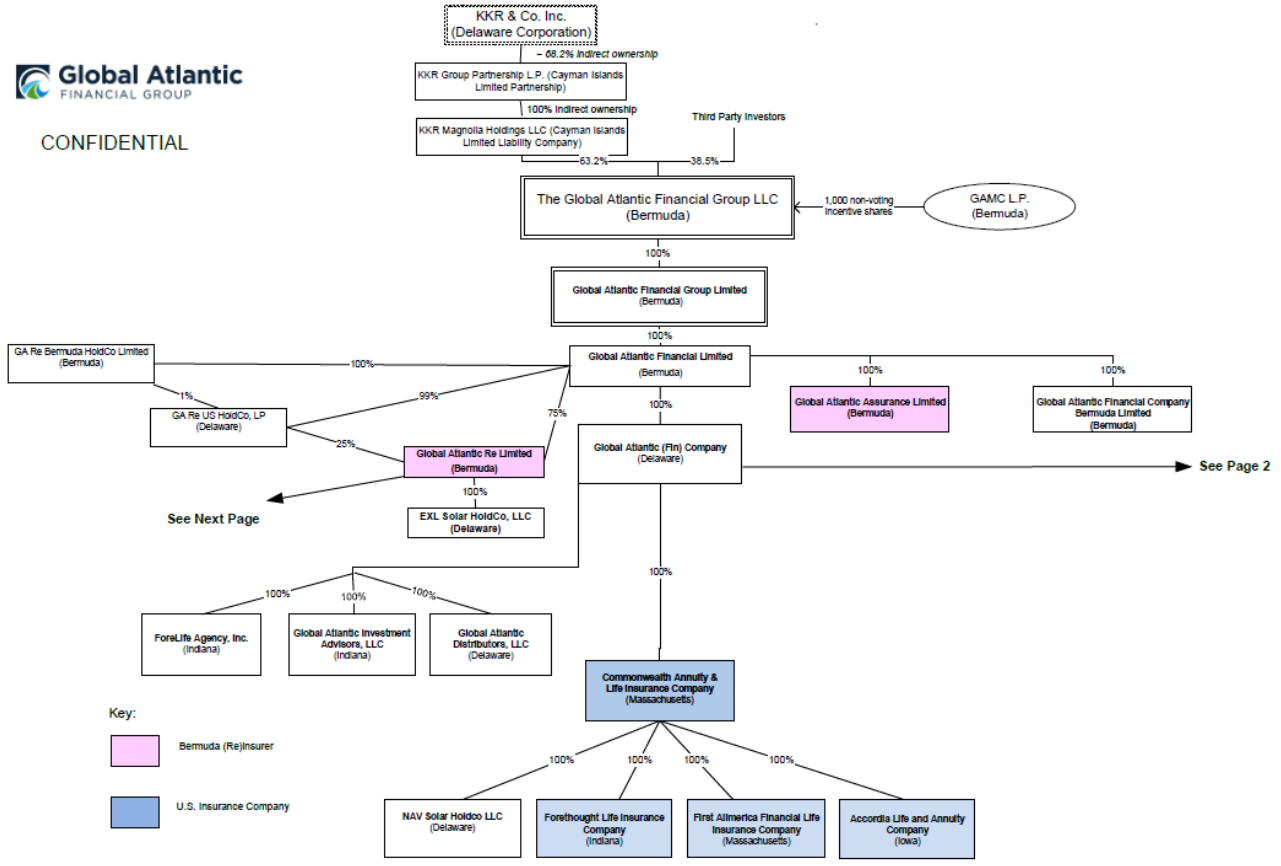

CONFIDENTIAL

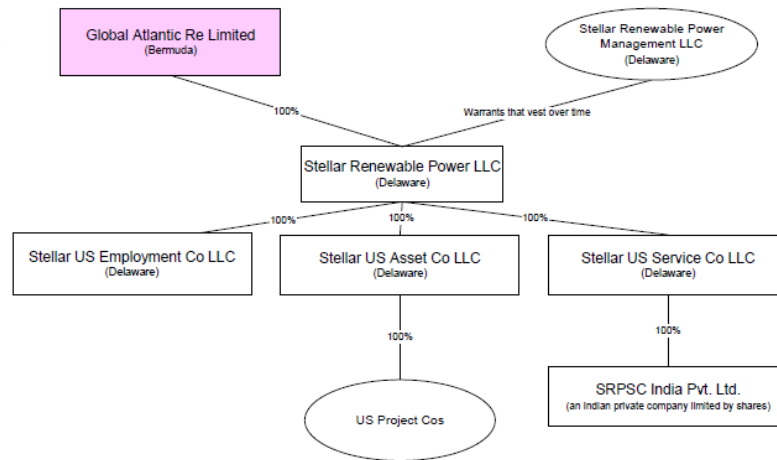
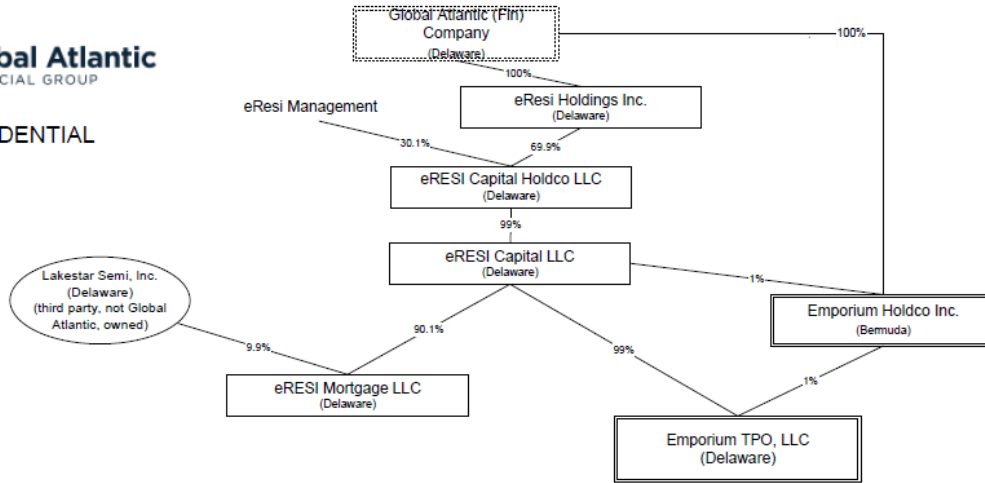

#### f. Insurance Business Written by Business Segment and by Geographical Region

The Company has issued Funding Agreements (Guaranteed Investment Contracts, or “GIC”) and Funds Withheld funding agreements (“FWH funding agreements” or “Synthetic Guaranteed Investment Contracts”, or “Synthetic GIC”), to an affiliated counterparty (each of which are deemed to be an ‘insurance contract’ under the Insurance Act) and has assumed through reinsurance life blocks from non-affiliated counterparties. All business written in is U.S, Hong Kong or Singapore-based.

Reinsurance accounting is applied for ceded and assumed transactions when U.S. GAAP risk transfer provisions have been met. To meet risk transfer requirements, a long-duration reinsurance contract must transfer mortality or morbidity risks and subject the reinsurer to a reasonable possibility of a significant loss.

Those contracts that do not meet risk transfer requirements are accounted for using deposit accounting. The funding agreements the Company issued are considered insurance contracts under the Bermuda Insurance Act of 1978, as amended, and these are accounted for as investment contracts as they are not life contingent. Deposit accounting is applied for investment contracts. The FWH funding agreements are considered derivative contracts under US GAAP and reported as investment contracts under Bermuda Statutory.

## **g. Performance of Investments & Material Income & Expenses for the Reporting Period**

### **Premiums and Other Income**

Premiums decreased \$1 million from \$31 million for 2021 to \$30 million for 2022. The small decrease in premiums was driven by normal run-off of business related to mortality risk assumed.

### **Performance of Investments**

GAAL generates revenue from its investment portfolio through net investment income and through funds withheld funding agreements issued. Total invested assets decreased \$3,066 million or 25% from \$12,079 million in 2021 to \$9,013 million in 2022. The decrease in total invested assets reflects both the increased market interest rates impacting fixed maturity securities which compose the Company's core type of invested assets and expected run off on block reinsurance assets.

GAAL follows prudent investment guidelines through a strategy that seeks to maximize returns while managing investment risk in line with the The Global Atlantic Financial Group LLC's overall objectives of earnings stability and long-term book value growth. The Company regularly reviews the allocation of investments to asset classes within the investment portfolio and allocates investments to those asset classes which we anticipate will overperform in the future, subject to limits and guidelines. Similarly, we also reduce exposure where deemed necessary.

### **Available for Sale ("AFS") Fixed Maturity Securities**

AFS fixed maturity securities are generally recorded on a trade-date basis and are carried at fair value. Impairment associated with AFS fixed maturity securities is recognized as an allowance for credit losses. The allowance for credit losses is established either by a charge to net investment losses in the statements of income, for securities identified as credit impaired after purchase, or by a gross-up recognition of an initial allowance for purchased credit deteriorated ("PCD") securities.

The fair value of the Company's total AFS fixed maturity securities decreased \$2,235 million, or 28%, from \$7,953 million 2021 to \$5,718 million 2022.

The distribution of the Company's AFS fixed maturity securities by type is as follows:

As of December 31, 2022	Cost or amortized cost	Allowance for credit losses	Gross unrealized		Fair value
			gains	losses	
<i>(\$ in millions)</i>					
<b>AFS fixed maturity securities portfolio by type:</b>					
U.S. government and agencies	\$106	-	-	\$(39)	\$67
U.S. state, municipal and political subdivisions	312	-	-	(65)	247
Corporate	3,571	-	1	(936)	2,636
RMBS	1,150	(15)	3	(132)	1,006
CMBS	931	(1)	-	(103)	827
CLOs	247	-	-	(15)	232
CBOs	392	-	-	(36)	356
Other	380	(1)	1	(33)	347
<b>Total AFS fixed maturity securities</b>	<b>\$7,089</b>	<b>\$(17)</b>	<b>\$5</b>	<b>\$(1,359)</b>	<b>\$5,718</b>

As of December 31, 2021	Cost or amortized cost	Allowance for credit losses	Gross unrealized		Fair value
			gains	losses	
<i>(\$ in millions)</i>					
<b>AFS fixed maturity securities portfolio by type:</b>					
U.S. government and agencies	\$ 279	\$ -	\$ 3	\$ (2)	\$ 280
U.S. state, municipal and political subdivisions	271	-	3	(1)	273
Corporate	3,902	-	15	(68)	3,849
RMBS	1,293	(6)	24	(17)	1,294
CMBS	992	-	1	(9)	984
CLOs	448	-	-	(1)	447
CBOs	388	(2)	-	(5)	381
Other	447	(2)	5	(5)	445
<b>Total AFS fixed maturity securities</b>	<b>\$ 8,020</b>	<b>\$ (10)</b>	<b>\$ 51</b>	<b>\$ (108)</b>	<b>\$ 7,953</b>

### Trading fixed maturity securities

The Company accounts for certain fixed maturity securities as trading, based on intent or via the election of the fair value option at acquisition. Trading securities are generally recorded on a trade-date basis and are carried at fair value, with realized and unrealized gains and losses reported in net investment-related gains (losses) in the statements of income. Interest income from these securities is reported in net investment income. Trading securities, which are primarily used to back funds withheld payable at interest



where the investment performance is ceded to reinsurers under the terms of the respective reinsurance agreements.

The fair value of the Company's total trading fixed maturity securities was \$1,571 million and \$2,269 at December 31 2022 and 2021, respectively. The trading securities back the funds withheld payable from a 2021 transaction whereby the Company entered into an agreement with a third party retrocessinaire for a quota share of whole life policies assumed.

The distribution of the Company's trading fixed maturity securities by type is as follows as of the dates indicated:

As of December 31, 2022 (Successor)	Cost or amortized cost	Gross unrealized		Fair value
		gains	losses	
<i>(\$ in millions)</i>				
<b>Trading fixed maturity securities portfolio by type:</b>				
U.S. government and agencies	\$65	\$-	\$(25)	\$40
U.S. state, municipal and political subdivisions	10	-	(1)	9
Corporate	2,022	176	(825)	1,373
RMBS	44	-	(8)	36
CMBS	58	-	(9)	50
CLOs	0	-	-	-
CBOs	74	-	(11)	63
Other Structured Securities	-	-	-	-
<b>Total trading fixed maturity securities</b>	<b>\$2,273</b>	<b>\$176</b>	<b>\$(879)</b>	<b>\$1,571</b>

### Held to Maturity ("HTM") Fixed Maturity Securities

The cost or amortized cost and fair value for HTM fixed maturity securities were as follows:

As of December 31, 2022	Cost or amortized cost	Gross unrealized		Fair value
		gains	losses	
<i>(\$ in millions)</i>				
CLOs	8	-	-	8
<b>Total HTM fixed maturities securities</b>	<b>\$8</b>	<b>\$-</b>	<b>\$-</b>	<b>\$8</b>

As of December 31, 2021	Cost or amortized cost	Gross unrealized		Fair value
		gains	losses	
<i>(\$ in millions)</i>				
CLOs	12	-	-	12
<b>Total HTM fixed maturities securities</b>	<b>\$ 12</b>	<b>\$ -</b>	<b>\$ -</b>	<b>\$ 12</b>

### Mortgages and Other Loan Receivables

The Company participates in mortgage and other loan receivables, and these loans are carried at cost, less the allowance for credit losses and as adjusted for amortization/accretion of premiums/discounts. The allowance for credit losses is established either by a charge to net investment losses in the statements of income or, for PCD mortgage and other loan receivables, by a gross-up recognition of the initial allowance in the balance sheets.

The value of the Company's total Mortgages and other loans increased \$435 million, or 33%, from \$1,290 million in 2021 to \$1,734 million in 2022 due to business growth and reinvestment into this asset class.

Mortgage and other loan receivables consist of the following:

<i>(\$ in millions)</i>	As of December 31,	
	2022	2021
	<i>Successor</i>	<i>Successor</i>
Commercial mortgage loans	\$1,076	\$659
Residential mortgage loans	652	639
Other loan receivables	6	1
<b>Total mortgage and other loan receivables</b>	<b>\$1,734</b>	<b>\$1,299</b>
Allowance for loan losses	(18)	(8)
<b>Total mortgage and other loan receivables, net of allowance for loan losses</b>	<b>\$1,716</b>	<b>\$1,291</b>

## Derivative instruments

The Company issued a series of funds withheld funding agreements to an affiliate, which are reported under U.S. GAAP as derivatives and held at fair value and each of which are deemed to be an 'insurance contract' under the Insurance Act.

The Company also has embedded derivatives related to reinsurance contracts that are accounted for on a modified coinsurance and funds withheld bases. An embedded derivative exists because the arrangement exposes the reinsurer to third-party credit risk. These embedded derivatives are included in funds withheld payable at interest in the balance sheets.

As of December 31, the fair value and notional value of the derivative assets and liabilities on a U.S. GAAP basis were as follows:

As of December 31, 2022 (Successor)	Notional value	Derivative assets	Derivative liabilities
(\$ in millions)			
Funds withheld funding agreements	\$ -	\$ -	\$ -
Fair value included within total assets	\$ -	\$ -	\$ -
Interest rate swaps	\$ 213		\$ 3
Total return swaps	\$ 14,671		\$ 1,478
Embedded derivative – funds withheld at interest	\$ -		\$ (736)
Fair value included within total liabilities	\$ -		\$ 745

As of December 31, 2021 (Successor)	Notional value	Derivative assets	Derivative liabilities
(\$ in millions)			
Funds withheld funding agreements	\$ 15,103	\$ 555	\$ -
Fair value included within total assets		\$ 555	\$ -
Embedded derivative – funds withheld at interest			\$ (54)
Fair value included within total liabilities			\$ (54)

## Net investment income

Net investment income increased by \$90 million, or 45%, from \$199 million in 2021 to \$289 million in 2022, primarily driven by the higher interest rate environment and timing of new business growth in 2021 and 2022.

	December 31, 2022 (Successor)		December 31, 2021 (Successor)	
	Carrying value	Return	Carrying value	Return
<i>(\$ in millions)</i>				
Fixed maturity securities – interest and other income	\$ 5,818	\$ 336	\$ 7,965	\$ 224
Trading securities – dividends and other income	1,571	-	2,269	-
Mortgage and other loan receivables	1,623	63	1,290	28
Income ceded from funds withheld at interest	(1,735)	(80)	(2,460)	(34)
Derivative assets	(1,479)	-	555	-
Short-term and other investment income	334	5	-	6
<b>Total invested assets</b>	<b>\$ 6,132</b>	<b>\$ 324</b>	<b>\$ 9,620</b>	<b>\$ 224</b>
Less: investment expenses				
Less: Investment management and administration		\$ 35		\$ 25
<b>Net invested assets</b>	<b>\$ 6,132</b>	<b>\$ 289</b>	<b>\$ 9,620</b>	<b>\$ 199</b>

## Net Investment Gains and Losses

Net investment gains decreased by \$2,011 million, from \$57 million in 2021 to \$(1,953) million in 2022. The higher interest rate environment drove unrealized losses on assets underlying the Company's FWH funding agreements, while the mark to market of the funding agreement liabilities are not recorded to the income statement. This mark to market of FWH Funding Agreements is not recorded on the Company's other accounting bases.

	December 31, 2022 (Successor)		December 31, 2021 (Successor)	
	Carrying value	Net investment gains/(loss)	Carrying value	Net investment gains/(loss)
<i>(\$ in millions)</i>				
AFS fixed maturity securities	\$5,818	\$(78)	\$7,965	\$(4)
Trading fixed maturity securities	1,571	(8)	2,269	(49)
Derivative (losses) gains	1,623	(1,215)	555	60
Funds withheld payable at interest	(1,735)	31	(2,460)	47
Mortgage and other loans	(1,479)	(11)	1,290	3
Short-term and other investment income	334	(672)	-	-
<b>Total invested assets</b>	<b>\$6,132</b>	<b>\$(1,953)</b>	<b>\$9,620</b>	<b>\$57</b>

### **Policy Benefits and Claims**

The Company's primary expense arises from interest credited to contract holders of funding agreements during the period. Policy benefits and claims decreased by \$32 million, from \$175 million in 2021 to \$143 million in 2022 primarily due to the restructuring and maturation of certain of the funding agreements in 2022 and the timing of the 2021 business growth.

### **Amortization of Policy Acquisition Costs**

Amortization of policy acquisition costs increased \$50 million, from \$34 million in 2021 to \$84 million in 2022. The increase in amortization of policy acquisition costs was primarily driven by the write-off of a restructured GIC's value-of-business-acquired insurance intangible, in which management determined an extinguishment.

### **Operating Expenses and Insurance Expenses, net of amounts capitalized**

Expenses increased by \$7 million, or 88%, from \$8 million in 2021 to \$15 million in 2022, driven by operating expenses related to incurring a full year of the costs of supporting the business growth.

### **h. Any Other Material Information**

None identified.

## Section II – Governance Structure

In addition to the requirements codified in legislation (including the Companies Act 1981, as amended and Insurance Act 1978, and related rules and regulations), common law and the Company's constitutional documents, the Company defines governance as the establishment and enforcement of key principles, policies, and committee oversight of risks across the business unit and the wider Global Atlantic organization ("Enterprise"). These are described through the Company's Risk Appetite Principles, Committee & Governance Framework and highlighted in the Company's Risk Culture Program. The Board of Directors ("GAAL Board" or "Board") has ultimate oversight of strategy and top risks facing the Company's business.

The Company's corporate governance framework provides appropriate oversight using a framework which ensures the proper identification and mitigation of risks. Management is tasked with day-to-day running of the business and responding to risks with oversight by the Board. The entity level governance structure is further supported by the Enterprise-wide Global Atlantic governance and risk management framework.

The Company believes in assigning ownership of risks throughout all areas of the organization and emphasizes risk and investment management as a differentiating factor relative to the Company's competitors. The Company utilizes the "three lines of defense" model that spans all departments and activities of the Enterprise. The Company participates in this strategy and utilizes Enterprise-wide control functions to identify and mitigate risks.

The first line of defense is the business. Individuals responsible for producing revenues for the business closely monitor risks that come with such business.

The second line of defense is the oversight and control functions of the organization – both control function departments, such as Legal/Compliance and Finance, as well as group level committees designed to identify, assess, and monitor risks in the business. The control role of committees such as Global Atlantic Risk Committee, the Global Atlantic Management Committee, the Global Atlantic Board and the GAAL Board are key control mechanisms within this line of defense. Through the design of controls, tracking and regular reporting to management and Global Atlantic and subsidiary Board Committees, the Company ensures that senior executives and Board members are promptly notified of emerging risks.

The third line of defense is Internal Audit. It's mission is to independently assess the Company's internal control structure, raise awareness of control risks and provide advice to management for enhancing controls and monitoring the implementation of new controls. Internal Audit is independent of the activities it audits, and the scope of its work is not subject to restrictions imposed by management. The Company's Bermuda operations are in scope for Internal Audit, which has direct access to the Board.

## **a. Board and Senior Executives**

### **i. Board and Senior Executive Structure, role, responsibilities, and segregation of responsibilities**

#### ***Board of Directors***

The Company's Board of Directors has ultimate oversight of strategy and material risks facing the business. The Company's Board has broad powers in accordance with Section 27 of the Company's By-laws and the Companies Act 1981, as amended. In addition to setting and executing the strategic direction, the Board considers growth opportunities and oversees in-force business, and key audit functions. The Board manages and monitors the performance of the external auditors and reviews their recommendations. Internal Audit reports its audit findings to the Board. The Board typically meets semi-annually and as of December 31, 2022, had 4 directors:

- Darryl Herrick, President and Head of Origination, GAAL
- Alberto Autmezguine, Managing Director and Chief Financial Officer, GAAL
- Jane Grosso, Senior Vice President and Chief Accounting Officer, GAAL
- Kymn Astwood, Senior Vice President and Chief Operating Officer, GAAL

Senior members of management set the strategic direction relative to the Company's risk tolerances, which the Board reviews and approves. Risk and investment management topics are featured prominently in Board materials and discussions.

Key management resides in Bermuda, including the President and Head of Origination, Chief Financial Officer, Chief Operating Officer, Chief Accounting Officer, Chief Actuary and Chief Risk Officer.

### **ii. Remuneration Policy**

#### ***Compensation Philosophy and Objectives***

As of December 31, 2022, Bermuda resident staff and members of the Board were employees of Global Atlantic Financial Company Bermuda Limited ("GAFGBL"). The remuneration policy follows that of the Global Atlantic corporate policy. Global Atlantic established a compensation and reward philosophy designed to ensure that the Company is able to attract, develop and retain exceptional talent. The primary goals of the Company's compensation programs are to (i) align employees' interests with those of shareholders and other stakeholders while at the same time protecting policyholders and clients, (ii) attract, motivate and retain employees of high ability to meet the needs of a rapidly evolving business, (iii) link pay to performance, and (iv) reward the achievement of individual goals that contribute to increases in shareholder value.

The compensation philosophy aligns incentives with this culture by supporting its Risk Appetite Principles; it is the foundation of its talent assessment and management approach. Collaboration, risk ownership and risk management shape nearly every aspect of the Company's activities. At the outset of the year, there is a robust goal setting process at the line of business, division, and individual levels to align objectives and targets to corporate and company goals. The annual performance management process heavily focuses on risk assessment and management as well as results achieved against goals set. Global Atlantic's defined performance management and compensation programs are reviewed annually with the Global Atlantic Board of Directors.

The compensation programs consist of a base salary, annual bonus, and equity. In particular, the Company's equity programs reflect its philosophy regarding the importance of aligning risk management and executive compensation. This equity ownership aligns employees with the interests of policyholders and, the long-term success of the business, which creates a clear incentive to appropriately manage risk.

### **iii. Pension or Early Retirement Schemes for Members, Board and Senior Employees**

At this time, GAAL has no employees. If in the future GAAL employs at least one eligible individual, a pension plan and other benefits will be established. Currently, employees' pension and other benefits are provided through Global Atlantic Financial Company Bermuda Limited ("GAFC BL"). GAFC BL offers eligible employees two defined contribution pension plans for the purpose of providing retirement income and increased savings. Employees of GAFCBL are eligible to participate in one of two retirement savings plans based on citizenship. Funds are invested based on the employee's preference amongst offered mutual funds available through the plans' record keepers. Vesting of company contributions across the two plans; occurs immediately. All plans are subject to regulatory limits. At this time, early retirement plans are not offered.

### **iv. Shareholder Controllers, Persons who Exercise Significant Influence, the Board or Senior Executive Material Transactions**

None.

## **b. Fitness and Propriety Requirements**

### **i. Fit and Proper Process in assessing the Board and Senior Executives**

The Company maintains a hiring and vetting process to confirm fitness and propriety for relevant individuals in line with the BMA's prudential regime for regulated entities, which includes consideration as to whether the person has relevant experience, skills, and knowledge to fulfill the particular duties and responsibilities of the position. The Company appoints members of the Board based on the individual's expertise and work experience as well as professional judgement. The senior management team is authorized to hire staff to ensure there is sufficient expertise to achieve their respective area's goals. The Chief Executive Officer is responsible for Senior Executive hires. The Global Atlantic Human Resources Department arranges background screening and other support for all hires to ensure appropriate organizational alignment. Subsequent to hiring, senior executives are regularly assessed against established performance objectives on an annual basis at a minimum, through the Enterprise's standard performance management process which reflect integrity, competency, and ability, to ensure they remain fit and proper.

### **ii. Board and Senior Executives Professional Qualifications, Skills, and Expertise**

#### ***Board of Directors***

#### **Darryl Herrick, President and Head of Origination, Global Atlantic Assurance Limited**

Darryl Herrick is responsible for expanding and broadening Global Atlantic's customer base and providing innovative and customized structuring solutions for clients. Mr. Herrick has been a key business leader for the Company since 2014. Mr. Herrick has more than 20 years of experience in the financial



services industry. Immediately prior to joining GAAL, he was a Partner with C12 Capital Management where he spearheaded new business development and portfolio management in reinsurance, mortgage, and regional bank investments. He held previous leadership positions at Barclays Capital and Goldman Sachs. Mr. Herrick earned his bachelor's degree in economics and finance from Boston College.

**Alberto Autmezguine, Managing Director, Chief Financial Officer, Global Atlantic Assurance Limited**

Alberto Autmezguine oversees all financial reporting, accounting, and actuarial matters for GAAL. Mr. Autmezguine has over 25 years of experience in the insurance and reinsurance industry. Immediately prior to joining GAAL in September 2021, he was President and CEO of Oceanview Reinsurance Ltd., a startup reinsurance company in Bermuda, where he spearheaded the formation and growth of the company. He held previous leadership positions at Prudential Financial, including Head of Individual Annuity Valuation. Prior to Prudential, he spent more than 10 years at ACE Tempest Life Reinsurance in various roles including SVP, Chief Actuary and Treasurer. Mr. Autmezguine earned his bachelor's degree in actuarial mathematics from Concordia University and he is a Fellow of the Society of Actuaries and a member of the American Academy of Actuaries.

**Jane Grosso, Chief Accounting Officer, Global Atlantic Re Limited**

Jane Grosso is responsible for the accounting functions of GAAL and leads reinsurance transaction accounting support. From 2016 to 2021 she also served as Chief Financial Officer. Prior to her roles at the Company, Ms. Grosso served as Controller for two of the Company's U.S. affiliates, directing the accounting processes and reinsurance accounting transactions for the prior 10 years. Ms. Grosso held finance and accounting leadership positions at John Hancock, Sun Life of Canada, and UNUM. Ms. Grosso earned a bachelor's degree from Brandeis University and an MBA in Finance from New York University's Leonard N. Stern School of Business.

**Kymn Astwood, Chief Operating Officer, Global Atlantic Assurance Limited**

Kymn Astwood is a Director and Secretary of GAAL and is also responsible for GAAL's treasury and reinsurance operations. Kymn joined the Goldman Sachs reinsurance effort in 1999 and spent most of his time in Global Atlantic's property and casualty reinsurance business, which was sold in 2015. Prior to joining Goldman Sachs, Kymn was Bermuda's Registrar of Companies and Chief Insurance Regulator. He also worked with Ernst & Young auditing insurance and reinsurance companies in Bermuda. Kymn is a CPA and earned a bachelor's degree in commerce from Saint Mary's University.

**Company Management**

**Andrew Shainberg, Chief Compliance Officer, Global Atlantic Assurance Limited**

Andrew Shainberg is the Chief Compliance Officer and General Counsel for Ethics of Global Atlantic Financial Group. Andrew, who joined Global Atlantic in July 2018 and has 30 years of experience in the insurance industry as both an attorney and compliance officer, is responsible for regulatory compliance for Global Atlantic and its subsidiaries. In November 2020, he assumed responsibility for Global Atlantic's Ethics program. Immediately prior to joining Global Atlantic, Andrew served as the Chief Compliance Officer of the Individual Markets division of The Guardian Life Insurance Company of America. Before that, Andrew

served as the Chief Compliance Officer of Prudential's Individual Life Insurance and Retail Distribution businesses.

**Chunhong Gao, FSA, MAAA, Chief Actuary, Global Atlantic Assurance Limited**

Chunhong Gao joined Global Atlantic Financial Group in 2014 and worked in the Boston Actuarial team with increasing responsibilities in actuarial matters for the institutional business, including supporting GAAL actuarial matters. In February 2022, Ms. Gao transferred to Global Atlantic Financial Limited (Bermuda) and was appointed as the Approved Actuary of GAAL. Prior to joining Global Atlantic, Ms. Gao worked at Sun Life and John Hancock. Ms. Gao earned a master's degree in actuarial science from Boston University and a bachelor's degree in mathematics from Fudan University. She is a Fellow of the Society of Actuaries and a member of the American Academy of Actuaries.

**Jan Spindler, Chief Risk Officer, Global Atlantic Assurance Limited** (Chief Risk Officer from 05/10/2022 to 8/22/2022)

Jan Spindler became the Chief Risk Officer of GAAL effective May 10<sup>th</sup>, 2022, and resigned from the Company on August 22, 2022. Mr. Spindler joined Global Atlantic Re Limited Bermuda in February 2022 as Chief Risk Officer Bermuda. He has experience across the (re)insurance industry including capital management, valuation and risk management across a broad range of products. Prior to his role at Global Atlantic, Mr. Spindler worked at Hannover Re Bermuda as the Chief Risk officer. During a 13 year 13-year tenure with Hannover Re, he worked in various roles in Germany and Bermuda. Mr. Spindler is a member of the German Actuarial Society (DAV) and Certified Enterprise Risk Actuary (CERA). He holds a Diploma in Mathematics from the Westfälische Wilhelms-Universität Münster (Germany).

**Julie McDonald, Chief Risk Officer, Global Atlantic Assurance Limited** (appointed effective 04/24/2023)

Julie McDonald is the Chief Risk Officer of GAAL effective April 24, 2023. Ms. McDonald joined Global Atlantic as Chief Risk Officer of the Bermuda operating companies in February 2023. Julie has over 10 years' experience across the life insurance and reinsurance industry including risk management and capital management. Prior to her role at Global Atlantic, Ms. McDonald held a senior pricing role at Partner Reinsurance. Ms. McDonald earned a bachelor's degree in actuarial science. She is a Fellow of the Institute and Faculty of Actuaries.

**Manu Sareen, Chief Executive Officer, Global Atlantic Assurance Limited**

Manu Sareen is Co-President and Head of Institutional Markets for Global Atlantic and Chief Executive Officer of GAAL. Mr. Sareen is responsible for driving Global Atlantic's growth through reinsurance and block acquisitions. Prior to the spinout of Global Atlantic, Mr. Sareen was a Managing Director in the Goldman Sachs Reinsurance Group (GSRG). Previously, he worked in the investment banking group at Wasserstein Perella and helped start CashEdge, a leading provider of internet-based payment services. Mr. Sareen is a member of the Advisory Board at the Massachusetts Institute of Technology ("MIT") Golub Center for Finance and Policy. Mr. Sareen graduated from Cornell University with a bachelor's degree in engineering and earned an MBA from the MIT Sloan School of Management.

### **c. Risk Management and Solvency Self-Assessment**

#### **i. Risk management process and procedures to identify, measure, manage and report risk exposures**

Global Atlantic has adopted a comprehensive Enterprise Risk Management program that formalizes systematic review of financial and non-financial risks and establishes risk management controls throughout the organization. Global Atlantic has a risk taxonomy that helps employees identify all types of risk that could affect the organization, establishes a common language to facilitate aggregation of risks across the Company and provides the system needed to enable comparative risk analysis over time. Once identified, risks throughout the organization are assessed and measured, through the annual Risk and Control Self-Assessment Process and through formal stress testing.

The Company monitors risks on an aggregate, and product basis, monitoring different factors, including financial, insurance, and operational risks to confirm that its risks remain within its established risk limits and tolerances.

The Company manages risk exposures and the suite of risk limits and early warning levels within its Risk Appetite Framework. The Risk Appetite Framework is designed to ensure the Company is able to fulfill its obligations to policyholders, maintain a position of strength, and protect franchise value, under stressed environments. Global Atlantic manages risk exposures through its asset-liability management program, hedging program, liquidity risk management program, reinsurance, and the suite of risk limits and early warning levels within its Risk Appetite Framework. The Risk Appetite Framework begins with Risk Appetite Principles that guide all aspects of management's goal-setting and decision-making processes and sets the "tone at the top" to drive risk awareness practices throughout the Company.

The Risk Committee of the Global Atlantic Board is dedicated to oversight of the group's risk management framework. The Risk Committee provides oversight and review of risk management policies and guidelines, and regularly reviews Global Atlantic's financial and non-financial risks through comprehensive quarterly reports that cover all insurance operating companies, including GAAL.

Global Atlantic also has a management-level Risk Committee that manages, evaluates, and oversees all material financial and non-financial risks affecting the Enterprise, at the aggregate group level and individually for the insurance operating companies, including GAAL.

#### **ii. Risk management and Solvency Self-Assessments Systems Implementation and Integration**

GAAL performs a Solvency Self-Assessment to ensure that it has adequate capital and liquidity to meet its business objectives and capital commitments. The Company reviews capital adequacy on a Bermuda regulatory basis and also assesses capital adequacy with regard to modified U.S. Statutory guidelines. The Solvency Self-Assessment tests and tracks exposures under a suite of formally defined stress scenarios.

The results of the Solvency Self-Assessment provide the Board, Risk Committee and management with insights into the key risks and current and future capital requirements.

### **iii. Relationship between Solvency Self-Assessment, Solvency Needs and Capital, and Risk Management**

GAAL maintains a capital profile that the Company believes supports the risks inherent in its business and allows it to meet its business objectives and contractual commitments. The Company's capital allocation strategy is derived from its Risk Appetite Principles. GAAL's Solvency Self-Assessment incorporates all material risks identified and assists in decision-making related to the management of risk in accordance with its Risk Appetite Principles. The Company forecasts Available Capital and Risk Capital positions over a three-year time horizon. Such multiyear assessment incorporates business plans from each line of business within GAAL. The results of GAAL's Self-Assessment are considered by the Board and management when reviewing the Company's strategy and approving new business.

### **iv. Solvency Self-Assessment Approval Process**

On an annual basis, the Company's Chief Operating Officer directs the preparation of the Solvency Self-Assessment report, with support from the Chief Risk Officer and servicing teams in Risk Management, Investments, and other relevant functions. The report is discussed extensively with management before presentation to the GAAL Board. On a semi-annual basis, the GAAL Board reviews liquidity and solvency metrics prepared by GAAL's Chief Risk Officer. In addition, as part of the GAAL Board's review and approval of a new business opportunity, senior management will review with the Board liquidity and solvency metrics reflecting the incorporation of the new business.

## **d. Internal Controls**

### **i. Internal Control System**

Management is responsible for establishing and maintaining adequate internal control. The Company's internal control system was designed to provide reasonable assurance to management and the GAAL Board regarding data and reporting. Management relies on the Internal Audit function to routinely assess the effectiveness of the Company's system of internal control.

### **ii. Compliance Function**

The Enterprise Compliance Department is responsible for overseeing compliance with applicable laws and regulation by providing support for the Enterprise, including GA Re. The objective of the Compliance Department is to be a fully integrated partner that supports all business operations and drives integrity-based business practices. Compliance is the responsibility of every employee.

The Enterprise and its businesses are subject to and must comply with numerous laws and regulations, most of which are promulgated and enforced by insurance departments of the jurisdictions in which the Enterprise's insurance operating companies are domiciled and licensed. Due to the Enterprise's product lines, investment activities and ownership structure, it is also subject to regulation by other governmental agencies and regulatory entities, including the U.S. Securities and Exchange Commission and the Financial Industry Regulatory Authority.

Policies and procedures are the means to ensure consistent operating guidelines that support the Enterprise in complying with applicable laws and regulations. The Compliance Department is responsible for creating, implementing and maintaining comprehensive compliance policies and procedures. Policies are readily accessible to all employees.

The Compliance Testing Group (“CTG”) provides an enterprise-wide testing program that focuses on maintaining compliance with applicable laws and regulations and proactively identifying issues for continuous improvement across the organization. CTG strives to protect the financial well-being and reputation of the Enterprise through the management of regulatory risks across all business areas. CTG works closely with the business area to identify deficiencies and to recommend areas for enhancement.

The testing strategy deployed by CTG is a risk-based approach that encompasses an annual review of the Enterprise’s key risk and control areas. CTG accomplishes this through discussions with key business partners (Legal, Operations, Risk Management, Internal Audit, etc.), identification and documentation of key regulations and existing controls, and review of complaint and litigation topics, legal and regulatory trends, regulatory priorities, market conduct findings, and relevant industry news. Based on this annual review, a testing calendar is established focusing on reviews relating to key areas of risk and operational processes that have regulatory compliance impact.

The Compliance Department is also responsible for overseeing the Enterprise’s regulatory change management program. The program utilizes a vendor tool system that identifies amended and new laws and regulations that may impact the Enterprise’s insurance operations. Through the system, Compliance personnel are notified of new and/or amended laws and regulations, assess their potential impact to the Enterprise, and ascertain and assign any actionable requirements to the appropriate function, which may be an internal department (e.g., Operations) or external partner (e.g., third party administrator). Compliance then utilizes the vendor system to track completion and follow-up on these action items.

All employees are required to complete Code of Conduct training upon joining TGAFG, and they are required to complete Annual Code of Conduct training. In addition, all employees are required each year to certify their compliance with the Code of Conduct. This process is handled and tracked by Compliance.

There is a dedicated regulatory examinations function within the Compliance Department, which is committed to providing the resources and data to aid examiners in the process of conducting thorough and efficient regulatory exams. In support of this philosophy, the Compliance Department has developed a repeatable exam process, and the Enterprise strives to respond promptly and fully to regulatory exam requests.

#### **e. Internal Audit**

The Global Atlantic Internal Audit department's mission is to assess the Global Atlantic internal control structure, raise awareness of control risk, provide advice to management in developing control solutions and monitor the implementation of management's control measures. Internal Audit assists Global Atlantic in accomplishing its objectives by bringing a systematic and disciplined approach to evaluate and improve the effectiveness of its risk management, control, and governance processes. Internal Audit reports to the Global Atlantic Audit Committee and provides support in fulfilling their oversight responsibilities. Internal Audit is independent of the activities it audits and the scope of its work is not subject to restrictions imposed by management.

The Internal Audit plan is developed using a risk-based methodology, including input of senior management and the Global Atlantic Audit Committee. At least annually, the Chief Audit Executive submits to senior management and the Global Atlantic Audit Committee an Internal Audit plan for review and approval. The Internal Audit plan consists of a schedule of planned audits (which includes GAAL functions and business processes) as well as budget and resource requirements for the next calendar year.

#### **f. Actuarial Function**

GAAL's Chief Actuary reports directly to the Chief Financial Officer of the Company. The GAAL Chief Actuary participates in the review of actuarial balances and changes related to quarterly financial results and the annual assumption review process. The GAAL Chief Actuary is responsible for setting, monitoring, and adjusting the Company's technical provisions.

#### **g. Outsourcing**

##### **i. Outsourcing Policy and Key Functions that have been outsourced**

GAAL has hired an external firm to provide skilled resources highly familiar with the Bermuda regulatory requirements to perform the loss reserving specialist function for its mortgage insurance business. The Company also utilizes a Bermuda registered insurance management company to be its Principal Representative.

In evaluating proposed vendor or outsourcing relationships, the Company participates in the Global Atlantic vendor selection processes, including due diligence and contract negotiation. Vendors are assigned a risk categorization based upon criteria including confidentiality of information and potential impact on the Company's business. Each vendor is assigned a Vendor Relationship Owner who owns the day-to-day relationship and provides input to the annual review of high-risk vendors. At each Board meeting, a review of operational risks is presented to the Board. In addition, the Chief Operating Officer presents periodic reviews of the risks associated with managing outsourcing arrangements.

##### **ii. Material Intra-Group Outsourcing**

GAAL leverages Enterprise-wide resources to support certain production and specialty functions across Global Atlantic affiliates. The Company utilizes investment managers at KKR to manage its portfolios. Under intercompany servicing agreements, the Company receives support for Operations, Finance, Risk and Actuarial with oversight from GAAL executives of each of these functions. The majority of the Company's reinsurance business is assumed from affiliates and significant cost efficiency is achieved through utilizing affiliate resources. In addition, the Company relies on Global Atlantic for Information Technology, Human Resources, Internal Audit and Compliance functions.

#### **h. Other Material Information**

No additional material information to report.

## Section III – Risk Profile

### a. Material Risk the Insurer is Exposed to During the Reporting Period

The Company's main risks fall into three categories: Financial Risk, Insurance Risk, and Operational Risk. Financial Risk can be further divided into Market, Credit, and Liquidity risk categories. Operational Risk includes Strategic Risk, Business Operations and Technology Risk, and Legal and Regulatory risk.

- Market Risk – the risk of loss or adverse change in the Company's financial situation resulting, directly or indirectly, from fluctuations in the level or volatility of equity markets, interest rates or market prices of financial instruments.
- Credit Risk - the risk of loss or adverse change in the Company's financial situation, resulting from the deterioration of the credit quality or default of an issuer of a financial instrument, or a counterparty in a reinsurance or derivative contract.
- Liquidity Risk – the risk of not being able to meet obligations when they come due as a result of the lack of sufficient liquid assets, the inability to sell assets without incurring significant losses, or the difficulty of raising capital when needed.
- Insurance Risk – the risk of loss arising from inadequate pricing or an adverse change in the value of insurance liabilities due to inadequate provisioning assumptions such as policyholder behavior uncertainties.
- Strategic Risk - the risk of loss arising from the adverse effect of management decisions on both business strategies and their execution, as well as from unexpected changes in environmental trends that damage the operating economics of the business.
- Business Operations and Technology Risk– the risk of loss arising from inadequate or failed internal or outsourced processes, personnel, or systems, or from external events.
- Legal and Regulatory Risk – the risk that U.S. regulators may fail to approve reinsurance transactions from U.S. cedants that are U.S. affiliates, or the risk that the Company fails to meet Bermuda regulatory requirements. The BMA rules are evolving and may introduce higher capital requirements for GAAL based on the current book of business. This is compounded by volatility given the market sensitivity of the Solvency II-type EBS framework when compared to US NAIC RBC. This may lead to the Bermuda BSCR requirements exceeding US NAIC RBC or other requirements.

The Company uses a combination of proprietary and vendor models to evaluate and quantify these risks, whenever quantifiable and monitors the exposure to assure adherence with the established Risk Appetite framework.

### b. Risk Mitigation in the Organization

As previously described, the Company has established Risk Appetite Principles that guide all aspects of Management goal-setting and decision-making processes and are the foundation of its risk management practices. Risk Appetite Principles are cascaded through the organization by the establishment of risk limits for financial exposures. Exposures to stress scenarios are evaluated quantitatively against these limits and results are regularly reviewed with the Board or the respective Board Committees. Should there be a temporary breach in established limits, escalation is required to the relevant Global Atlantic committees and GAAL management for development of mitigation solutions and tracking.

The Company evaluates non-financial risks by their potential impact to its business which is reported to the Board. Appropriate tracking and follow-up are established to ensure that risks are addressed or incorporated into ongoing monitoring and reporting. New or emerging risks are identified through the Company's risk identification process and regular update of the risk inventory, once identified, adequate mitigating measures are established.

As the Company grows its book of business via acquisition of additional inforce reinsurance, new products, new investment opportunities etc., opportunities are evaluated in respect to risk thresholds established and the contractual commitments in place. Forecasts incorporating each new opportunity and associated risk exposures are discussed with the Board.

#### **c. Material risk concentrations**

The Company has policies governing risk concentrations in relation to counterparties, credit quality, sectors, and geographical locations. Apart from highly rated sovereigns and associated sponsored agencies, the Company has single name issuer limits by rating class, including credit and derivative exposure. Counterparty exposure is monitored by the Risk team and reported at each Board meeting. The Company is currently in compliance with this policy.

#### **d. Investment in assets in Accordance with the Prudent Person Principles of the Code of Conduct**

Concurrent with the acquisition of the Company's ultimate parent, The Global Atlantic Financial Group LLC (TGAFGL), by Kohlberg Kravis Roberts (KKR) & Co. Inc., GAAL appointed Kohlberg Kravis Roberts & Co. L.P. (KKR IM) to be the investment manager for its capital assets. KKR IM has also been appointed as the investment manager of a majority of the funds withheld assets related to reinsurance business assumed or ceded. The Company maintains an investment strategy consistent with its past practices and guidelines.

KKR manages the majority of the Company's investment portfolios, allowing the Company to leverage KKR's industry-leading expertise, broad range of investment services and strong origination capabilities. Investment guidelines on funds withheld portfolios are carefully crafted with input from the group's investment team. The Company maintains unencumbered assets investment guideline; for example, sector and single issuer targets that limit exposure to idiosyncratic risks of a sector or individual counterparties. Furthermore, the Company's Board closely monitors compliance with investment guidelines. The approach of KKR, Global Atlantic, and the Company, embody the prudent person approach as set out in the BMA's Insurance Code of Conduct.

#### **e. Stress Testing and Sensitivity Analysis to Assess Material Risks**

A key component of the capital assessment framework is the institutionalization of the Company's Risk Appetite Principles throughout its decision-making processes. The Board reviews capital adequacy quarterly. To the extent relevant, special capital and risk topics are also reviewed on an ad-hoc basis by the Board.

In assessing whether the Available Capital position is sufficient to support the material risks, the Company stresses those factors which have the greatest impact on Available Capital and Risk Capital. The models and tools the Company has developed allow it to stress these different risk factors and observe the effects on both its assets and liabilities, where both are affected in a consistent manner.



Through a combination of thorough analysis of externally published macroeconomic scenarios (e.g. Federal Reserve Supervisory Scenarios), prior market cycles, internal meetings and meetings with external macroeconomic researchers, the Company has developed firm-wide deterministic scenarios that describe three different macroeconomic states: Base, Downside, and Extreme Downside (collectively, “Enterprise Scenarios”). The Company has analyzed and defined how different market factors react in these macroeconomic states, as well as the correlation between different market factors in these states. Market factors cover interest rates, equities, credit (spreads, rating migration and defaults) and liquidity. To the extent that insurance risks are correlated to market risks, their impacts are also accounted for within the Company’s Enterprise Scenarios. Other macroeconomic factors to which the Company may be exposed include home prices and inflation indices, which are further described in each Enterprise Scenario.

Based on the latest results, management believes that the Company has sufficient capital and liquidity to comply with the contractual obligations of the organization and regulatory requirements, even upon experiencing losses within its risk tolerance.

## Section IV – Solvency Valuation

### a. Valuation Bases, Assumptions and Methods to Derive the Value of Each Asset Class

The Company has used the valuation principles outlined by Bermuda Monetary Authority's "Guidance Note for Statutory Reporting Regime" for the reporting period's statutory filing. The economic valuation principles outlined in this document are to measure assets and liabilities on a fair value basis (which is the value that would be received upon the sale of an asset or paid to transfer a liability in an orderly transaction between open market participants at the measurement date). The fair value principles used for the assets are applied to both the general account and FWH receivable as follows:

- Cash and cash equivalents include cash on hand, amounts due from banks, money market securities, highly liquid overnight deposits, discount notes and commercial paper held in the ordinary course of business. The Company considers all short-term highly liquid investments with original maturities of less than three months to be cash and cash equivalents. Cash and cash equivalents are recorded in cash and cash equivalents in the Balance Sheets at cost, which approximates fair value

- Fixed Maturity Securities – which include bonds and structured securities are valued at fair value. Fair value is based on quoted market prices where available. When quoted market prices are not available, the Company estimates fair value by discounting debt security cash flows to reflect interest rates currently being offered on similar terms to borrowers of similar credit quality (private placement debt securities), by quoted market prices of comparable instruments (untraded public securities) and by independent pricing sources or internally developed pricing models. Equities - includes common stock and is valued using the quoted market prices.

- The fair value of mortgages and other loans are estimated by discounting future cash flows using current rates at which similar loans would be made to borrowers with similar credit ratings and for the same remaining maturities.

- For policy loans with fixed interest rates, estimated fair values are determined by using discounted cash flow models applied to groups of similar policy loans determined by the nature of the underlying insurance liabilities. Cash flow estimates are developed by applying a weighted-average interest rate to the outstanding principal balance of the respective group of policy loans and an estimated average maturity determined through experience studies of the past performance of policyholder repayment behavior for similar loans. These cash flows are discounted using current risk-free interest rates with no adjustment for borrower credit risk as these loans are fully collateralized by the cash surrender value of the underlying insurance policy. The estimated fair value for policy loans with variable interest rates approximates carrying value due to the absence of borrower credit risk and the short time period between interest rate resets, which presents minimal risk of a material change in estimated fair value due to changes in market interest rates.

- Accounts Receivable and Premium Receivable – are recorded at a fair value and balances due in more than one year have been discounted at the relevant risk-free rate.

- FWH Receivable and Payable: On an EBS basis, Funds held under reinsurance contracts are valued at the quoted market prices of the underlying portfolio of assets referenced in the reinsurance agreement. FWH Funding Agreements are valued as FWH reinsurance consistent with EBS valuation principles for FWH reinsurance contracts. The Company's FWH Funding Agreements are accounted for as derivatives under U.S. GAAP. The fair values of these derivatives under US GAAP are consistently valued, primarily based on the fair value of the underlying investments. The fair values of these securities are determined using quoted market prices in active markets or other observable inputs to pricing. For EBS the FWH Funding Agreements are included in Funds Withheld Receivable and BEL and are not reported as derivatives. The Company's derivative instruments are primarily used to hedge interest rate risk. Where certain criteria are met, some of these hedging arrangements may achieve hedge accounting.

## **b. Valuation Bases, Assumptions and Methods to Derive the Value of Technical Provisions**

Insurance technical provisions are based on best estimate plus a risk margin to reflect the uncertainty inherent in the underlying cash flows. The risk margin is calculated using the cost of capital approach and a risk-free discount rate term structure. The discount rate term structures are prescribed by the BMA for each reporting period. Below are descriptions of the methodology for calculating Best Estimate for Long-Term Business.

### **Methodology for Calculating Best Estimate for General Business**

As of December 31, 2022 the Company has not written any General Business and related BEL and Risk Margin is nil.

### **Methodology for Calculating Best Estimate for Long-Term Business and Risk Margin**

The Best Estimate Liability ("BEL") for Long-Term Business (including life insurance and fixed annuity business) is calculated under the Scenario-based approach. The asset requirement for all blocks is summed and the BEL is set to the highest asset requirement of all scenarios prescribed by the BMA.

The Risk Margin is calculated using the cost of capital method, which reflects the cost of holding an Enhanced Capital Requirement level of capital in respect to insurance risk, credit risk and operational risk. The template supplied by the BMA, which reflects a 6% cost of capital, is used directly.

## Long-Term Business Insurance Technical Provisions

	As of December 31,	
	2022	2021
<i>(\$ in millions)</i>		
<b>Total Gross Long-Term Business Insurance Provisions</b> Best Estimate Liability (Form 1EBS, Page 2, Line 27(a))	\$19,013	\$23,518
<b>Reinsurance Recoverable Balance from Domestic Affiliates</b> Best Estimate Liability (Form 1EBS, Page 2, Line 27(b)(i))	\$0	\$0
<b>Reinsurance Recoverable Balance from Other Insurers</b> Best Estimate Liability (Form 1EBS, Page 2, Line 27(b)(i))	\$1,332	\$1,871
<b>Net Long-Term Business Insurance Provisions</b> Best Estimate Liability (Form 1EBS, Page 2, Line 27(d))	\$0	\$0
<b>Risk Margin - Long-term insurance business</b> Best Estimate Liability (Form 1EBS, Page 2, Line 27A)	\$42	\$67
<b>Technical Provisions - Long-term insurance business</b> Best Estimate Liability (Form 1EBS, Page 2, Line 27C)	\$17,723	\$21,713

In 2022, GAAL entered into the following transactions:

- A FWH funding agreement with an affiliate
- Reinsurance of multiple life policies with a third party, Singapore cedant

Assumptions are reviewed by the Company each year and updated as needed.

### c. Description of Recoverables from Reinsurance Contracts

The recoverable from the ceded reinsurance contract is based on the BEL calculation for the ceded liability under the scenario-based approach. The BEL calculation reflects the future projected benefit and expense cash flows that have been ceded which the Company expects to recover from the reinsurer that has assumed the liability. The Company has assessed the counter party credit risk to be de-minimis.

### d. Valuation Bases, Assumptions and Methods to Derive the Value of Other Liabilities

The Company values all other liabilities in accordance with the valuation principles outlined by the BMA's "Guidance Note for Statutory Reporting Regime," which values liabilities at a fair value basis, and without adjustment for the Company's own credit standing. All other liabilities (with the exception of Funds Held under Reinsurance Contracts and Derivative Instruments) are valued on a U.S. GAAP basis. Funds held under reinsurance contracts are valued at the quoted market prices of the underlying portfolio of assets referenced in the reinsurance agreement. Derivative Instruments are valued at quoted market prices. In the absence of an active market, prices are based on observable market inputs.

### e. Any Other Material Information

No additional material information to report.

## Section V – Capital Management

### a. Eligible Capital

#### i. Capital Management Policy and Process for Capital Needs, how Capital is Managed and Material Changes During the Reporting Period

The Company's Risk Appetite Principles guide and shape its decision-making. The Company's first principle, to meet contractual obligations, requires the Company to maintain strong capital to honor the obligations in its reinsurance and insurance contracts under situations which reflect the worst modern economic cycles. The second principle, delivery of long-term value to the Company's stakeholders, requires that the Company maintains a position of financial strength during periods of adverse market conditions.

The Company assesses capital adequacy based on the Bermuda solvency requirements as well as certain U.S. statutory guidelines. The Company also considers its liquidity position and remediation steps in the event of stress. The Company reviews capital adequacy semi-annually with the Board. To the extent relevant, special capital and risk topics are also reviewed on an ad-hoc basis in Board meetings.

The key matters related to capital adequacy and risk management are discussed by Management at least semi-annually. The Company's ability to meet the Risk Appetite Principles and specific goals underlying those principals is the key focus of the risk topic at the Board meetings and is also closely discussed when evaluating new transactions.

There have been no material changes during the reporting period.

#### ii. Eligible Capital Categorized by Tiers in Accordance to the Eligible Capital Rules Used to Meet ECR and MSM Requirements of the Insurance Act

As of the reporting date, 100% of eligible capital is categorized as Tier 1, the highest quality of capital, consisting of capital stock, contributed surplus, and statutory surplus.

As of December 31, 2022, eligible capital for both Minimum Margin of Solvency ("MSM") and Enhanced Capital Requirement ("ECR") of \$2,427 million, was categorized as Tier 1 capital.

	As of December 31,	
	2022	2021
<i>(\$ in millions)</i>		
Tier 1	\$ 2,427	\$ 2,448
Tier 2	-	-
Tier 3	-	-
<b>Total eligible capital</b>	<b>\$ 2,427</b>	<b>\$ 2,448</b>

### iii. Confirmation of Eligible Capital that is Subject to Transitional Arrangements

None of the eligible capital is subject to transitional arrangements.

### iv. Identification of Any Factors Affecting Encumbrances on Availability and Transferability of Capital to Meet the ECR

The Company has entered into contracts with insureds or cedants that require it to collateralize certain obligations as scheduled or calculated by the counterparty. These assets are held in trust for the benefit of the Company's counterparties. The assets in trust are released as the liability to the counterparty runs off. Interest earned on assets in trust accrues to the Company's benefit.

### v. Identification of Ancillary Capital Instruments Approved by the Authority

Not applicable.

### vi. Identification of Differences in Shareholder's Equity as Stated in the Financial Statements Versus the Available Capital and Surplus

The variance between the U.S. GAAP Shareholder's Equity and Statutory Capital and Surplus was \$1,915 million and \$(84) million at December 31, 2022 and 2021, respectively. This variance is driven by the FWH funding agreements issued to an affiliate. While U.S. GAAP reports the transaction as a derivative, the Company has received an exemption under Section 6C of the Insurance Act of 1978 ("the Act") from the Bermuda Monetary Authority to account for the FWH funding agreement on the statutory financial statements as reinsurance rather than to apply ASC 815-15 as to the Financial Accounting Standard 133 DIG Issue A16. Given this modification, the FWH Funding agreements were recorded on the statutory financial statements at book value. Due to Purchase accounting the statutory financials were revalued to fair value at the acquisition date.

The Company's exemption under Section 6C of the Insurance Act of 1978 from application of ASC 815-15, more commonly known as Financial Accounting Standard 133 DIG Issue B36 (DIG B36") to its statutory financial statements and the resulting adjustments to Amortization of Acquisition Expenses and Deferred Revenues did not create a variance with U.S. GAAP in 2022 or 2021.

The following reflects other changes to Statutory Capital and Surplus:

(\$ in thousands)	As of December 31,	
	2022	2021
	Successor	Successor
U.S. GAAP Shareholder's Equity	\$ (1,015)	\$ 1,976
DIG A16 MTM	1,520	(529)
PGAAP MTM on FwH Funding Agreement	396	445
<b>Bermuda Statutory Capital and Surplus</b>	<b>\$ 901</b>	<b>\$ 1,892</b>

The differences between Statutory Capital and Surplus and Statutory Economic Capital & Surplus are caused by three valuation adjustments:

- The recording of economic-based technical provision valuation techniques,
- The release of insurance intangibles, which can be either capitalized expense or deferred revenue; and
- The adjustment to a fair value basis in accordance with statutory-based valuation techniques of certain assets not on a fair value basis for U.S. GAAP.

## b. Regulatory Capital Requirements

### i. ECR and MSM Requirements at the End of the Reporting Period

As of December 31, 2022 and 2021 the Company's regulatory capital requirements were:

	As of December 31,	
	2022	2021
<i>(\$ in millions)</i>		
Requirement;		
Minimum margin of solvency	\$ 375	\$ 416
Enhanced capital requirement	\$ 720	\$ 735

### ii. Identification of Any Non-Compliance with the MSM and the ECR

The Company was compliant with its MSM and ECR requirements at the end of the reporting period, and there were no instances of non-compliance.

### iii. A Description of the Amount and Circumstances Surrounding the Non-Compliance, the Remedial Measures and Their Effectiveness

Not applicable.

### iv. Where the Non-Compliance is not Resolved, a Description of the Amount of the Non-Compliance

Not applicable.

## c. Approved Internal Capital Model

Not applicable

## **Section VI – Subsequent Event**

The Company evaluated all events and transactions through April 24, 2023, the date the accompanying financial statements were available to be issued, that would merit recognition or disclosures in the financial statements, and determined there were none.